

PIPE INSTALLATION INSPECTION FORM

Project # _____ County, Route & Segment _____

Inspector _____ Installation Date _____

Item # _____ Ref. # _____ Producer Code _____ Contractor _____

Description _____

Station _____ Plan Page _____ Pipe Mat'l (RCP, Metal, HDPE, Iron, Other) _____

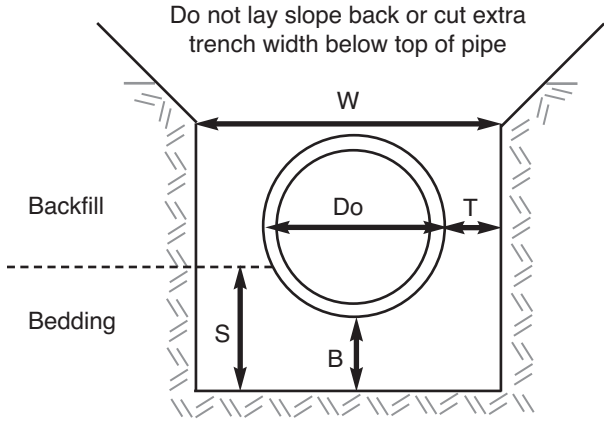

Pipe Size _____ inches
 W = Width of trench at Top of Pipe _____ feet
 Refer to RC - 30M
 Note: Trench or shoring walls to be vertical to Top of Pipe
 B = Thickness of bedding under pipe. _____ inches
 T = Outside diameter of pipe to trench wall. _____ inches
 S = Total Depth of bedding. _____ inches
 Do = Outside diameter of pipe _____ inches

Trench & Bedding Checks* (Actual Field Measurements)

Check Stations & Location	T	W	B	S	Do	Initial	Date

* Check every 50 feet, with a minimum of two checks per run.

Field Measurements (Depth - ft)	Grade Check Method (Ruler, laser)	Backfill (Document density using TR-478A or TR 4276A)						Inspector's Initials	Date
		Compaction Method/ Equipment	Soil or Aggregate Type	% passing 3/4" sieve	Lift Thickness (inches)	Density required (% SPD)	# compactor passes/lift		
0' - 3'						100 %			
3' -						%			
						%			
						%			

Type of Joints (601.3d) _____ Joints Installed Satisfactorily? Yes No

Materials: Certified or Tested and approved prior to incorporation into the project? Yes No

All pavement undermining cut back and removed prior to compaction? Yes No

Remarks: Record problems, soft foundations, under cuts, rock, obstructions, utilities encountered, deviations, etc. Describe and note location of existing conduits encountered, whether connected, plugged and abandoned, reconnected, etc.

Sketch Area:

A large grid of dashed lines for sketching, consisting of 20 columns and 10 rows of squares.

Inspector's Signature

Date

By signing below, I certify that my company performed the work, the information on both pages of this form is accurate, the work complied with Publication 408, including Section 601 and references therein, and any deviations are noted on this form.

Name (print): _____ Title: _____

Company Name: _____

Signature: _____ Date: _____